

ActivBoard 500 PRO Adjustable System

INTERACTIVE WHITEBOARD SYSTEM

Product Specifications



ActivBoard 500 Pro Adjustable
with PRM-30a or PRM-35 projector



ActivBoard 500 Pro Adjustable
with EST-P1 projector

THIS DOCUMENT CONTAINS SPECIFICATIONS FOR

ActivBoard
Adjustable Frame
Projector

DESCRIPTION

The ActivBoard 500 Pro with Dual-User Pen and Touch capability is available in 87" and 95" versions with integrated slim-line speakers and amplifier, ActivInspire Professional Edition, Promethean ActivOffice and Promethean Applications software. The Adjustable System includes a height-adjustable wall mount and choice of Extreme Short Throw or Short Throw projector.

SYSTEM OVERVIEW

Installation

The installation of this product should be completed by a Promethean Certified Installer. Please visit www.PrometheanWorld.com/ActivCare/installationtc. Components supplied and minimum specifications stated have been tested and are required for optimal performance. Use of components not supplied by Promethean or not meeting minimum specifications may impact performance and affect warranty. Contact your Promethean partner or visit www.PrometheanKB.com for more information

Warranty

For Promethean Warranty Information please visit: www.PrometheanWorld.com/ActivCare

Support

Online Support for all Promethean Products available from: www.PrometheanKB.com

Complete System Weight (approx.)

ActivBoard 587 Pro including;
PRM-30a Projector 107.8kg (237.2lb)
PRM-35 Projector 104.8kg (242.7lb)
ActivBoard 595 Pro including;
PRM-30a Projector 115.8kg (254.8lb)
PRM-35 Projector 112.8kg (248.2lb)

ActivBoard 587 Pro including;
EST-P1 Projector 108.1kg (237.8lb)
ActivBoard 595 Pro including;
EST-P1 Projector 116.1kg (255.4lb)

ActivBoard Systems/Boards SS 11/11 V2.0 US

©2011 Promethean Limited. All rights reserved. Promethean Ltd. is owner of a number of trademarks in several jurisdictions across the world. Any third-party product and company names are mentioned for identification purposes only and may be trademarks of their respective owners. ¹Applicable Terms and Conditions for warranty and support available at www.PrometheanWorld.com/ActivCare. All dimensions +/- 5mm (0.2in). All weights +/- 0.9kg (2lb). Product Specifications are subject to change without notice. www.PrometheanWorld.com



UPGRADE AND ACCESSORY OPTIONS

Cable Wall Box

Connectivity box with inputs for 2 x fully wired VGA (to support VESA DDC) plus 3.5mm stereo jack audio inputs, USB-B input (for ActivBoard), S-Video, composite video plus auxiliary audio jack inputs, Cat 5e Ethernet input. Allows additional flexibility during installation, where the computer is located further away from the System

ActivWand 50

Wireless, battery-free and extended reach input device for the ActivBoard – 540mm (21.2in) in length; “left click”, cursor and hover, just like a mouse

Dry Erase Whiteboard

Optional dry erase whiteboard, can use 1 or 2 dry erase whiteboards per System

ActivBoard System Shelf

Storage for 1 laptop, with a maximum size of a standard 43cm (17in) laptop. Lockable System Shelf also available as an option

TECHNICAL DRAWING

PRM-30a

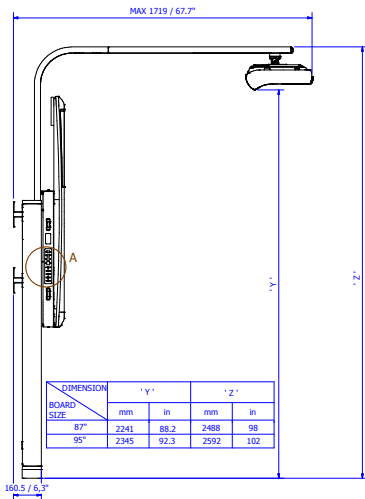

PRM-35

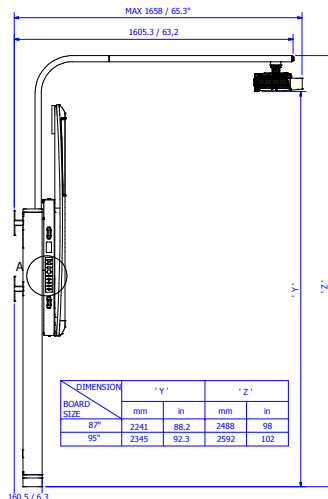

EST-P1

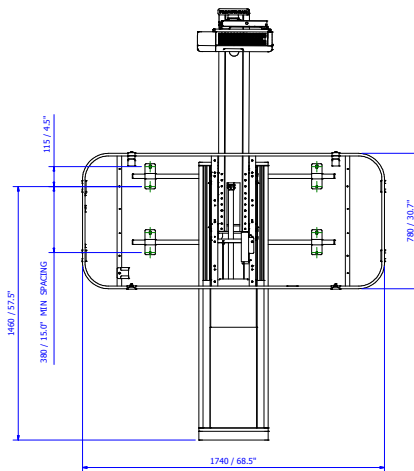
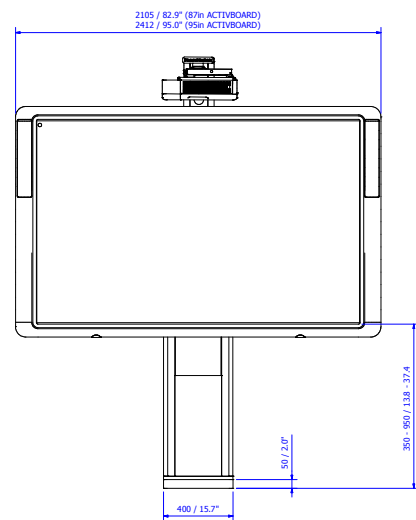
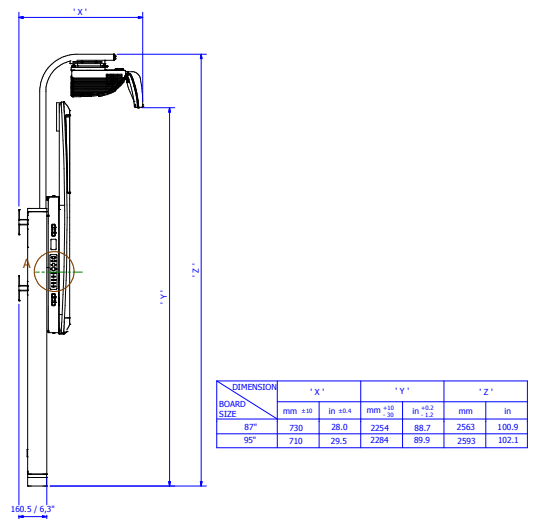

DETAIL A (1 : 2)

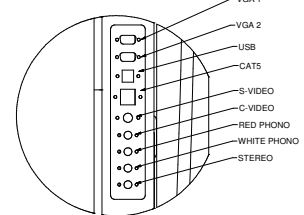

ACTIVBOARD GENERAL SPECIFICATIONS

Model	ActivBoard 500 Pro Range
Pen Internal Resolution	2730 points (lines) per inch
Pen Output Resolution	200 points (lines) per inch
Pen Tracking Rate	200 inches per second providing a fast response to pen commands
Pen Output Rate	160 coordinate pairs per second (single user) 80 coordinate pairs per second (dual user)
User Input	Cordless battery-free pen incorporating tip switch and side switch for full mouse functionality (ActivPen) and touch
Touch Resolution	200 points (lines) per inch
Touch Output Rate	80 coordinate pairs per second
Touch Response Rate	10 ms
Maximum Simultaneous Touches	2 with ActivInspire (Minimum requirement of 1.5 ActivInspire Professional Edition) 4 with Windows 7
Digitizing Technology	Passive Electromagnetic and Capacitive sensing interface
Power Requirement	Mains Powered; 18V Power Supply Unit
Connection to Computer	USB 2.0, 1 x 3m USB 2.0 data cable supplied
Connection to Peripherals	2 x USB ports on left hand side
Screen Surface	Low Glare Melamine
Certifications	UL, CE, FCC
Operating Temperature Range	0°C to +40°C (32°F to 104°F)
Storage Temperature Range	-20°C to +60°C (-4°F to 140°F)
Storage Humidity	10% to 90% (non-condensing)
Dual User Functionality	Pen: 1 Instructor ActivPen and 1 Participant ActivPen can be used together in Dual-User Mode when using ActivInspire 1.5 Professional Edition and above Pen and Touch: 1 Participant ActivPen and simultaneous additional two-touch gesture supported when using ActivInspire 1.5 Professional Edition and above
Single User Functionality	Pen: 1 Instructor ActivPen Touch: Two-touch gesture supported when using ActivInspire 1.5 Professional Edition and above
Integrated USB Sound	Two integrated slim-line speakers and amplifier (with controls, inputs and outputs)
Packed Contents List	ActivBoard 587 Pro or ActivBoard 595 Pro, 2 Instructor ActivPens, 2 Participant ActivPens, 1 AMP PSU, Wall Mounting Brackets, User Guide, Access to ActivInspire Professional Edition, Promethean ActivOffice and Promethean Applications via download. (ActivInspire Professional Edition is also available on DVD on request), 1 x 3m USB data cable

ActivBoard Systems/Boards SS 11/11 V2.0 US



©2011 Promethean Limited. All rights reserved. Promethean Ltd. is owner of a number of trademarks in several jurisdictions across the world. Any third-party product and company names are mentioned for identification purposes only and may be trademarks of their respective owners. ¹Applicable Terms and Conditions for warranty and support available at www.PrometheanWorld.com/ActivCare. All dimensions +/- 5mm (0.2in). All weights +/- 0.9kg (2lb). Product Specifications are subject to change without notice. www.PrometheanWorld.com

INTEGRATED USB SOUND SPECIFICATIONS

Amplifier Power Output	20W per channel RMS (<1% distortion)
Controls	Volume, Bass, Treble, on/off
Amplifier Frequency Response	40Hz to 18kHz +/-3dB (at 1W)
USB Sound	USB Sound supported for Minimum System Requirements stated
Connectivity – Inputs (4)	Stereo PC, Stereo CD/DVD, Mono Auxiliary, Microphone to PC
Connectivity – Outputs (2)	2 Stereo
Power Requirement	18V 5 Amp

ACTIVBOARD SPECIFICATIONS

Model	ActivBoard 587 Pro	ActivBoard 595 Pro
ActivBoard Size	87in	95in
Resolution	14600 x 9200	17200 x 9200
Screen Formats	16:10	16:9
Overall Dimensions	2105mm x 1329mm (82.9in x 52.3in)	2336mm x 1329mm (92in x 52.3in)
Active Area Dimensions	1865mm x 1175mm (73.4in x 46.3in)	2095mm x 1175mm (82.5in x 46.3in)
Active Area Diagonal	2196mm (86.5in)	2394mm (94.3in)
Actual Image Diagonal	2193mm (86.4in)	2392mm (94.2in)
Board Weight	40kg (88lb)	48kg (106lb)
Packed Weight	57kg (126lb)	65kg (143lb)
Packed Dimensions	2270mm x 1500mm x 110mm (89.4in x 59.1in x 4.3in)	2572 mm x 1495mm x 110mm (101.3in x 58.9in x 4.33in)

MINIMUM COMPUTER REQUIREMENTS

Operating Systems	Windows XP SP3 and above (XP/Vista/7); Mac OSX 10.4.11 – 10.6.4 (Tiger/Leopard/Snow Leopard); Linux Ubuntu 9.10 or 10.04; Debian Lenny; Linex Colegios 2010; Linkat 3; ALT_Linux (Russia)
PC	2.0 GHz Intel Core 2 Duo or faster for HD-quality videos, 1 GB of RAM is required to play HD-quality videos, 1024 x 768 resolution, 1.5 GB of Free Disk Space
Mac	2.0 GHz Intel Core 2 Duo, 512 MB of RAM, 1024 x 768 resolution, 3.0 GB of free disk space
Linux	2.0 GHz Processor or faster for HD-quality videos, 1 GB of RAM is required to play HD-quality videos, 1024 x 768 resolution, 1.5 GB of free disk space

ActivBoard Systems/Boards SS 11/11 V2.0 US

©2011 Promethean Limited. All rights reserved. Promethean Ltd. is owner of a number of trademarks in several jurisdictions across the world. Any third-party product and company names are mentioned for identification purposes only and may be trademarks of their respective owners. ¹Applicable Terms and Conditions for warranty and support available at www.PrometheanWorld.com/ActivCare. All dimensions +/- 5mm (0.2in). All weights +/- 0.9kg (2lb). Product Specifications are subject to change without notice. www.PrometheanWorld.com

Product Specifications

ADJUSTABLE FRAME SPECIFICATIONS

Projector Model	Short Throw	Extreme Short Throw
Height Settings	Height-adjustable mount, with 600mm (23.6in) of adjustment from 350mm (13.8in) to 950mm (37.4in) ± 50mm (1.9in). Top and bottom limit stops are fitted if the full range of movement is not required/appropriate. Height adjustment is powered by an electrical motor and is operated using a switch on the side of the stand	Height-adjustable mount, with 600mm (23.6in) of adjustment from 350mm (13.8in) to 950mm (37.4in) ± 50mm (1.9in). Top and bottom limit stops are fitted if the full range of movement is not required/appropriate. Height adjustment is powered by an electrical motor and is operated using a switch on the side of the stand
Projector Mount	Aluminum arm, extends 1605mm (63in) from the wall, adjusts with the height of the ActivBoard reducing the need for specific re-calibration following height adjustment	Aluminum arm, extends 550mm (21.7in) from the wall, adjusts with the height of the ActivBoard reducing the need for specific re-calibration following height adjustment
Room Height Requirements	Min. 2.66m (104.7in) for full range operation	Min. 2.66m (104.7in) for full range operation
Integrated Power Management	For ActivBoard, Projector and Actuator	For ActivBoard, Projector and Actuator
Actuator	<p>Input Voltage: 24VDC Max Load: 750N Static Load: more than 750N Speed: 30mm/s (no load), 20mm/s (750N) Stroke Length: 600 ± 2mm Retracted Length: 795 ± 2mm End Mounting Dimension: H Type, ø10.1 hole, 6.3mm Slot Limit Switch: Built-in Duty Cycle: S2-10min Temperature: -26° to 65°C IP Degree: IP54 AC-DC Adaptor: Input Voltage: 100 ~ 240VAC Output Voltage: 29VDC Current: 2Amp (4Amp protected) Cable and Plug: 1.5m, IEC Plug</p>	<p>Input Voltage: 24VDC Max Load: 750N Static Load: more than 750N Speed: 30mm/s (no load), 20mm/s (750N) Stroke Length: 600 ± 2mm Retracted Length: 795 ± 2mm End Mounting Dimension: H Type, ø10.1 hole, 6.3mm Slot Limit Switch: Built-in Duty Cycle: S2-10min Temperature: -26° to 65°C IP Degree: IP54 AC-DC Adaptor: Input Voltage: 100 ~ 240VAC Output Voltage: 29VDC Current: 2Amp (4Amp protected) Cable and Plug: 1.5m, IEC Plug</p>
Frame Weight (approx.)	62.1kg (136.6lb) excl. board, projector and cabling	59.1kg (130lb) excl. board, projector and cabling
Connectivity Panel	Connectivity panel with inputs for 2 x fully wired VGA (to support VESA DDC) plus 3.5mm stereo jack audio inputs, USB-B input (for ActivBoard), S-Video, composite video plus auxiliary audio jack inputs, Cat 5e Ethernet input. Connectivity panel can be mounted on the left or right-hand side of the frame	Connectivity panel with inputs for 2 x fully wired VGA (to support VESA DDC) plus 3.5mm stereo jack audio inputs, USB-B input (for ActivBoard), S-Video, composite video plus auxiliary audio jack inputs, Cat 5e Ethernet input. Connectivity panel can be mounted on the left or right-hand side of the frame

CONTINUED ON NEXT PAGE

ActivBoard Systems/Boards SS 11/11 V2.0 US

©2011 Promethean Limited. All rights reserved. Promethean Ltd. is owner of a number of trademarks in several jurisdictions across the world. Any third-party product and company names are mentioned for identification purposes only and may be trademarks of their respective owners. ¹Applicable Terms and Conditions for warranty and support available at www.PrometheanWorld.com/ActivCare. All dimensions +/- 5mm (0.2in). All weights +/- 0.9kg (2lb). Product Specifications are subject to change without notice. www.PrometheanWorld.com



ADJUSTABLE FRAME SPECIFICATIONS (CONTINUED)

Cables

Cable assembly includes; 2 x 4m (13.1ft) VGA panel mount (fully wired to support VESA DDC), 4m (13.1ft) S-Video panel mount, 4m (13.1ft) composite video panel mount, 4m (13.1ft) Ethernet panel mount, 2.8m (9.2ft) USB cable, 2.5m (8.2ft) right angle stereo jack to panel mount jack socket, 2.5m (8.2ft) right angle stereo jack to panel mount phono pair, for PC audio input. To connect the computer to the face plate: 2m (6.6ft) USB patch cable; and a 2m (6.6ft) VGA cable provided in the projector box

Cable assembly includes; 2 x 4m (13.1ft) VGA panel mount (fully wired to support VESA DDC), 4m (13.1ft) S-Video panel mount, 4m (13.1ft) composite video panel mount, 4m (13.1ft) Ethernet panel mount, 2.8m (9.2ft) USB cable, 2.5m (8.2ft) right angle stereo jack to panel mount jack socket, 2.5m (8.2ft) right angle stereo jack to panel mount phono pair, for PC audio input. To connect the computer to the face plate: 2m (6.6ft) USB patch cable; and a 2m (6.6ft) VGA cable provided in the projector box

Pack Weights & Dimensions

Box 1 of 3: 18.2kg (40lb)
 Dimensions: 217mm x 1427mm x 467mm
 (8.54in x 56.18in x 18.39in)
 Contents: Boom
Box 2 of 3: 22.6kg (49.7lb)
 Dimensions: 182mm x 1652mm x 442mm
 (7.2in x 65in x 17.4in)
 Contents: Spine
Box 3 of 3: 11.6kg (25.5lb)
 Dimensions: 128mm x 1782mm x 822mm
 (5.04in x 70.16in x 32.36in)
 Contents: Frame

Box 1 of 3: 15.6kg (34.3lb)
 Dimensions: 217mm x 1427mm x 467mm
 (8.54in x 56.18in x 18.39in)
 Contents: Boom
Box 2 of 3: 22.6kg (49.7lb)
 Dimensions: 182mm x 1652mm x 442mm
 (7.2in x 65in x 17.4in)
 Contents: Spine
Box 3 of 3: 11.6kg (25.5lb)
 Dimensions: 128mm x 1782mm x 822mm
 (5.04in x 70.16in x 32.36in)
 Contents: Frame

Product Specifications

PROJECTOR SPECIFICATIONS

Model	EST-P1 (DLP)	PRM-35 (DLP)	PRM-30a (LCD)
Native Resolution	WXGA (1280 x 800)	WXGA (1280 x 800)	WXGA (1280 x 800)
Compressed Resolution	up to 1080i	up to 1080i	up to 1080i
Typical Colors	16.77 million colors	16.77 million colors	16.77 million colors
Brightness (ANSI lumens)	2200 ANSI (normal) 2500 ANSI (high)	2100 ANSI (normal) 2500 ANSI (high)	1900 ANSI (normal) 2500 ANSI (high)
Contrast Ratio	2000:1	2000:1	500:1
Noise Level	27dB (normal) 31dB (high brightness mode)	32dB (normal) 36dB (high brightness mode)	29dB (normal) 36dB (high brightness mode)
Dimensions (w x d x h)	354mm x 319mm x 157mm (13.9in x 12.6in x 6.1in) not including lens 354mm x 411mm x 219mm (13.9in x 16.1in x 8.6in) including lens	306mm x 275mm x 97mm (12in x 3.8in x 10.1in)	382mm x 430mm x 129mm (15in x 16.9in x 5in)
Weight	9kg (19.8lb)	2.7kg (6lb)	5.7kg (12.5lb)
Aspect Ratio	16:10 (native), 4:3, 16:9	16:10 (native), 4:3, 16:9	16:10 (native), 4:3, 16:9
Power Consumption	290W (<1W standby)	230W (<1W standby)	317W (<0.8W standby)
Device Type	DLP Technology	DLP Technology	LCD Technology
Focus	Manual Focus	Manual Focus	Manual Focus
Zoom	N/A	Digital Zoom	Digital Zoom
Focal Length	F=2.4	F=2.86	Fixed
Projection Distance	0.39m ~ 0.56m (15in ~ 22in)	0.54m ~ 1.22m (21.3in ~ 48in)	0.54m ~ 1.22m (21.3in ~ 48in)
Projection Screen Size	1.98m ~ 2.79m (78in ~ 110in)	1.27m ~ 2.79m (50in ~ 110in)	1.27m ~ 2.79m (50in ~ 110in)
Lamp Type	220W lamp	230W lamp	230W lamp
Lamp Life	6000hrs (normal), 4000hrs (high)	6000hrs (normal), 4000hrs (high)	4000 hrs (normal), 3000 hrs (high)
Keystone Correction	Vertical: max ±15°	Vertical: max ±15°	Vertical: max ±20°
Operating Temperature	5°C ~ 35°C (41°F ~ 95°F)	5°C ~ 35°C (41°F ~ 95°F)	5°C ~ 35°C (41°F ~ 95°F)
Power Supply Voltage	100 - 240V AC, 50/60Hz	100 ~ 240V AC, 50/60Hz	100 ~ 240V AC, 50/60Hz
Horizontal Scan Rate	15Hz ~ 90kHz	15Hz ~ 90kHz	15Hz ~ 90kHz
Vertical Scan Rate	43Hz ~ 85Hz	50Hz ~ 85Hz	50Hz ~ 85Hz

CONTINUED ON NEXT PAGE

ActivBoard Systems/Boards SS 11/11 V2.0 US

©2011 Promethean Limited. All rights reserved. Promethean Ltd. is owner of a number of trademarks in several jurisdictions across the world. Any third-party product and company names are mentioned for identification purposes only and may be trademarks of their respective owners. ¹Applicable Terms and Conditions for warranty and support available at www.PrometheanWorld.com/ActivCare. All dimensions +/- 5mm (0.2in). All weights +/- 0.9kg (2lb). Product Specifications are subject to change without notice. www.PrometheanWorld.com



PROJECTOR SPECIFICATIONS (CONTINUED)

Computer Compatibility	IBM PC and Compatibles; Apple Macintosh, iMac, and VESA Standards WSXGA+ (1,680 x 1,050), WXGA+ (1,440 x 900), WXGA (1,280 x 800, 1,280 x 768), UXGA (1,600 x 1,200), SXGA+ (1,400 x 1,050), SXGA (1,280 x 1,024), XGA (1,024 x 768), SVGA (800 x 600), VGA (640 x 480)	IBM PC and Compatibles; Apple Macintosh, iMac, and VESA Standards WSXGA+ (1,680 x 1,050), WXGA+ (1,440 x 900), WXGA (1,280 x 800, 1,280 x 768), UXGA (1,600 x 1,200), SXGA+ (1,400 x 1,050), SXGA (1,280 x 1,024), XGA (1,024 x 768), SVGA (800 x 600), VGA (640 x 480)	IBM PC and Compatibles; Apple Macintosh, iMac, and VESA Standards WSXGA+ (1,680 x 1,050), WXGA+ (1,440 x 900), WXGA (1,280 x 800, 1,280 x 768), UXGA (1,600 x 1,200), SXGA+ (1,400 x 1,050), SXGA (1,280 x 1,024), XGA (1,024 x 768), SVGA (800 x 600), VGA (640 x 480)
Video Compatibility	NTSC (3.58/4.43), PAL (B/D/G/H/I/M/N), SECAM (B/D/G/K/K1/L), HDTV (720p, 1080i, 1035i), EDTV (480p, 575i), SDTV (480i, 576i)	NTSC (3.58/4.43), PAL (B/D/G/H/I/M/N), SECAM (B/D/G/K/K1/L), HDTV (720p, 1080i, 1035i), EDTV (480p, 575i), SDTV (480i, 576i)	NTSC (3.58/4.43), PAL (B/D/G/H/I/M/N), SECAM (B/D/G/K/K1/L), HDTV (720p, 1080i, 1035i), EDTV (480p, 575i), SDTV (480i, 576i)
Inputs/Outputs	D-sub 15 (RGB) x 2 D-sub 15 (Monitor out) x 1 HDMI V1.3 only for Video x 1 S-Video x 1 Composite Video (RCA) x 1 USB control x 1 Networking LAN (RJ45) x 1 RS-232C (D-sub 9) x 1	D-sub 15 (RGB) x 2 D-sub 15 (Monitor out) x 1 HDMI V.1.3 only for Video x 1 S-Video x 1 Composite Video (RCA) x 1 USB control x1 Networking LAN (RJ45) x 1 RS-232C (D-sub 9) x 1	D-sub 15 (RGB) x 1 D-sub 15 (RGB) selectable x 1 HDMI (Digital RGB) x 1 S-Video x 1 Composite Video (RCA) x 1 RCA (white/red) x 1 Networking LAN (RJ45) x 1 RS-232C (D-sub 9) x 1 Stereo mini-jack x 1
Color	Silver	Silver	Silver
Security	Kensington Lock, Security cable bar option, pin code security, remote control operated only	Kensington Lock, Security cable bar option, pin code security, remote control operated only	Kensington Lock, Security cable bar option, pin code security, remote control operated only
On-screen Menu	Arabic, Chinese (Simplified), Chinese (Traditional), Czech, Dutch, English, Finnish, French, German, Greek, Hungarian, Italian, Japanese, Korean, Norwegian, Polish, Portuguese, Russian, Spanish, Swedish, Thai, Turkish	Arabic, Chinese (Simplified), Chinese (Traditional), Czech, Dutch, English, Finnish, French, German, Greek, Hungarian, Italian, Korean, Norwegian, Polish, Portuguese, Russian, Spanish, Swedish, Turkish	Arabic, Chinese (Simplified), Chinese (Traditional), Danish, Dutch, English, Finnish, French, German, Hungarian, Italian, Japanese, Kazak, Korean, Norwegian, Polish, Portuguese, Portuguese (Brazilian), Romanian, Russian, Spanish, Swedish, Turkish
Advanced Features	Filter-less 3D Ready Crestron RoomView Express Quick Lamp Access Direct power on/off Closed Caption	Filter-less 3D Ready Crestron RoomView Express Quick Lamp Access Direct power on/off Closed Caption	Long Life Filter – 4000hrs Crestron RoomView Express Cable Management Cover Quick Lamp Access Direct power on/off Closed Caption
Packed Contents List	Projector, Power cord, computer cable (D-sub15 – D-sub15), wireless remote, owner's manual (CD - ROM & Quick Start Guide)	Projector, Power cord, computer cable (D-sub15 – D-sub15), wireless remote, owner's manual (CD - ROM & Quick Start Guide)	Projector, Power cord, computer cable (D-sub15 – D-sub15), wireless remote, owner's manual (CD - ROM & Quick Start Guide)
Pack Weights and Dimensions	Box 1 of 1: 13.5kg (29.7lb) Dimensions: 572mm x 496mm x 310mm (22.5in x 19.5in x 12.2in) Contents: Projector	Box 1 of 1: 4.9kg (10.8lb) Dimensions: 396mm x 341mm x 181mm (15.5in x 13.4in x 7.1in) Contents: Projector	Box 1 of 1: 9.5kg (20.9lb) Dimensions: 510mm x 470mm x 240mm (20in x 18.5in x 9.4in) Contents: Projector

ActivBoard Systems/Boards SS 11/11 V2.0 US

©2011 Promethean Limited. All rights reserved. Promethean Ltd. is owner of a number of trademarks in several jurisdictions across the world. Any third-party product and company names are mentioned for identification purposes only and may be trademarks of their respective owners. ¹Applicable Terms and Conditions for warranty and support available at www.PrometheanWorld.com/ActivCare. All dimensions +/- 5mm (0.2in). All weights +/- 0.9kg (2lb). Product Specifications are subject to change without notice. www.PrometheanWorld.com

